



Tractors

AXION

880 860 840 820



AXION 800 Series
More of everything.





Impressive in every way.

The AXION 800 in the 200 to 300 hp class offers an outstanding level of driving comfort and ease of operation that makes long working days seem shorter

More of everything.

- More help: the self-learning operator assistance system CEMOS makes your job so much easier
- More flexibility: with CEBIS you can view two cameras and control ISOBUS implements
- More flow: 54 gpm with Power Beyond standard
- More efficiency: Low engine RPM concept reduces fuel consumption
- More accuracy: One press of a button activates the PTO and revs the engine up to one of two preset engine rpm memories
- More comfort: a leather steering wheel, hands-free system and rear-opening roof hatch make for a more enjoyable working environment

The AXION 800 Series. Simply superior.

Simply productive.

A powerful 6.7L Tier 4F engine with deep torque reserves will power through tough spots in the field and steep grades on the road. An efficient CLAAS CMATIC (CVT) transmission with 31 mph travel speed make quick work of many different jobs. Standard high-flow, load sensing hydraulics ensure accurate and precise control of seed and chemical applications, and an optional front hitch and PTO are available for greater versatility. The CLAAS AXION 800 Series tractors are simply more productive – more acres per hour, more tons per day, more hours per year.

Simply efficient.

If your demands call for maximum speed under varied engine loads, our CMATIC CVT transmission is the perfect fuel saving option. Coupled with a multi-speed PTO system and a PROACTIV front suspended axle that transfers more power to the ground, the CLAAS AXION 800 Series tractors are simply more efficient – less gallons per acre, less hours per job, less cost per hour.

Simply comfortable.

With a standard four-point suspended cab, optional ventilated and heated leather seat, PROACTIV front axle, and shock absorbing front- and rear- three point hitches, the AXION 800 Series delivers premium comfort in spades. We understand that long hours – day and night, hot and cold, rain or shine – are mandatory, so our tractors deliver a quiet ride, LED lights that turn nighttime into daytime, curved glass and forward placed B-posts for the best visibility, automatic climate control, and a built in cool-box to keep you comfortable and refreshed. The CLAAS AXION 800 Series tractors are simply more comfortable – less fatigue, more time at work, better ride quality.





AXION CMATIC - Model overview	880	860	840	820
Rated HP PS, Engine, R-120	265/280*	250	230	215
Rated PTO HP SAE, OECD-2	224/240*	223	209	194
PTO HP SAE, OECD-2, at PTO rated speed	245/261*	244	225	209

*With boost engaged

The engine. Packaged for performance.

Strong at heart.

A 6-cylinder, 6.7 liter FPT (Fiat Powertrain Technologies) NEF 6 engine gets to work under the hood. The engine meets the requirements of the T4F emissions standard by incorporating exhaust gas aftertreatment with urea. It uses the latest common rail 4-valve technology, charge-air cooling, and a variable geometry turbo (VGT).

Constant output.

The CLAAS-specific engine performance curve provides full torque in a wide engine speed range, guaranteeing constant output and power delivery when they are needed. This makes it easy to save fuel while working at a low engine speed and maximum torque with the ECO PTO, or to work at rated speed with a full reserve.

Variable geometry turbo.

The VGT turbo delivers optimum charge-air pressure at any engine speed. It adjusts to load and engine speed, making 70% of maximum torque available even when idling. Optimized combustion therefore means low fuel consumption and maximum performance.

AXION 880 CMATIC.

The AXION 880 CMATIC delivers up to 290 hp thanks to the intelligent CLAAS POWER MANAGEMENT (CPM) electronic control system. Additional boost power is available for PTO work above 4.3 mph, for transport operations, and also for the fan drive, significantly increasing the performance and versatility of the AXION 880 CMATIC.

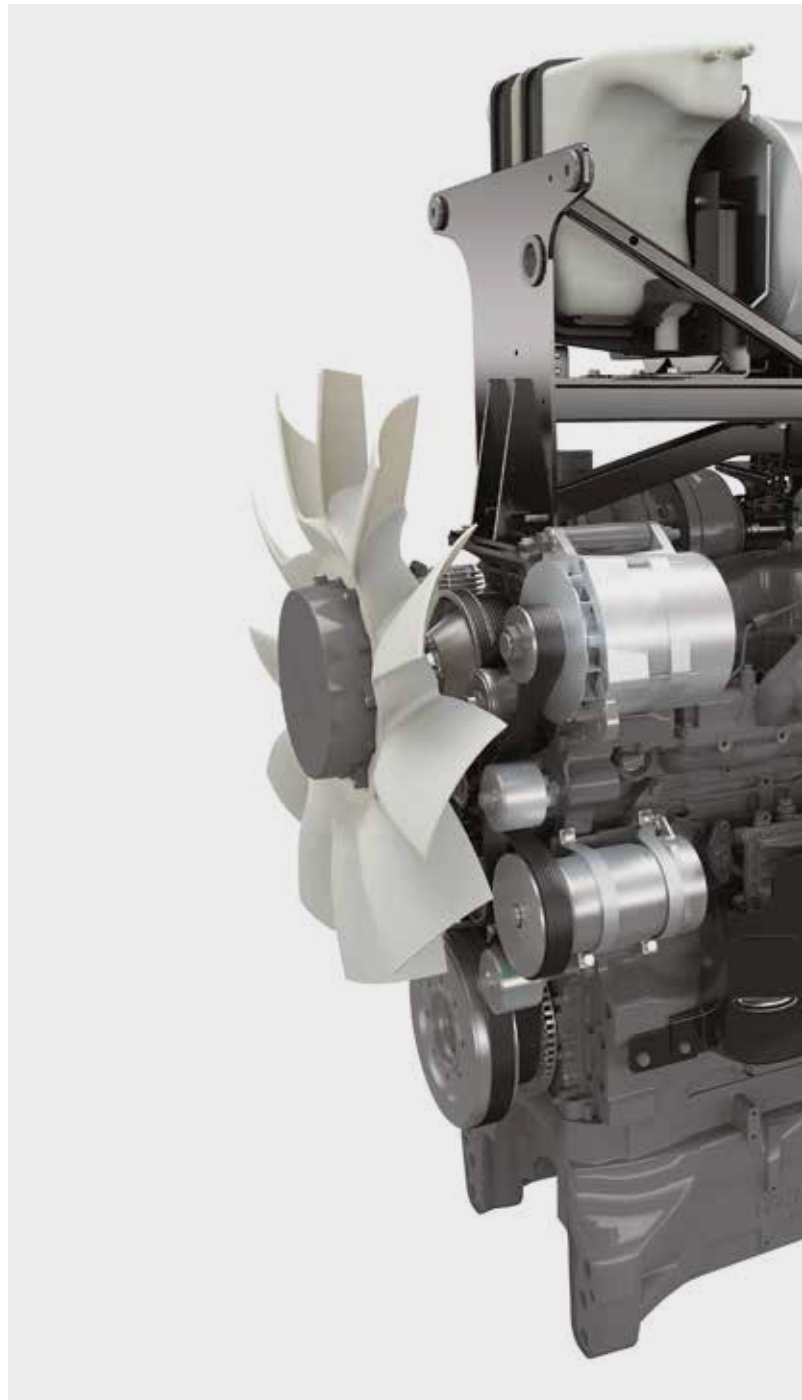

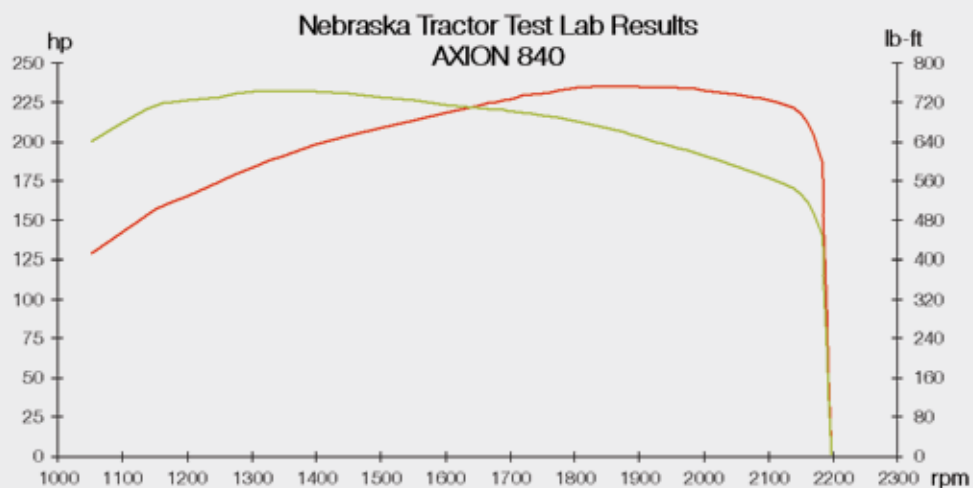
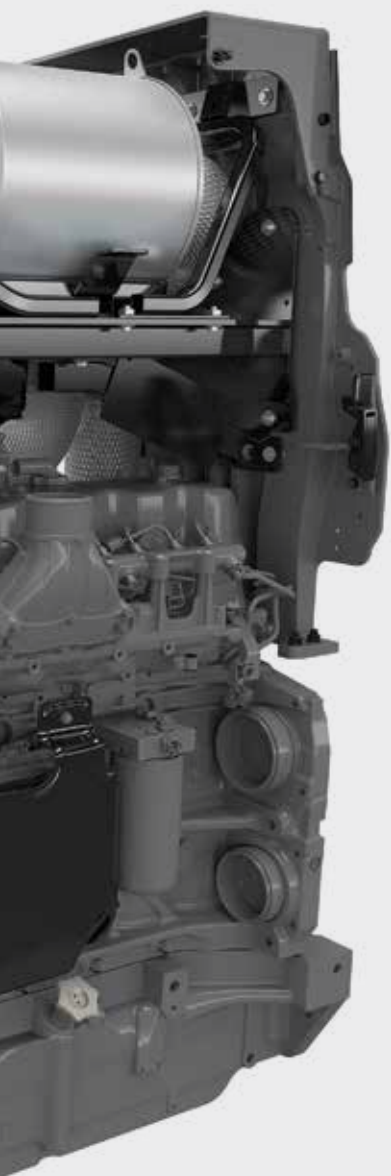

Visctronic – economical fan control.

With Visctronic fan control, the fan speed can be precisely aligned with engine temperature and load, directly linked to the engine ECU, ensuring that the engine always runs at the optimum temperature.

The reduced fan speed lowers the noise level and saves valuable fuel with no unnecessary impact on output, which can then be converted into tractive power.

Exhaust gas aftertreatment. Cleaning up.



SCR – the urea-based solution.

SCR stands for selective catalytic reduction, a process in which nitrogen oxides are converted into water and pure nitrogen. This is achieved by using a synthetic aqueous solution of urea (DEF), which is carried in an additional tank. Exhaust gas aftertreatment enables the combustion process in the engine to function at the optimum level.

Fully integrated SCR system.

When designing the AXION 800 Series, all the components required for exhaust gas aftertreatment were considered from the outset. The diesel oxidation catalytic converter (DOC) is positioned under the hood for optimum performance and improved visibility.

Never lets you down.

The urea tank is heated as standard and is also protected from the cold by the insulating effect of being integrated into the fuel tank. The SCR system lines are also emptied automatically when the engine is switched off to protect against freezing.



120 gal fuel tank with integrated 11 gal urea tank.

Shuttles.

Choose your preference.



Standard left-hand shuttle.



Right-hand reverser on the CMOTION handle.



Optional right-hand reverser on the ELECTROPILOT joystick.

Different shuttles. Different applications.

The shuttle in the AXION tractor is smooth, adaptable, and can be configured to be just where you need it most.

All AXION tractors have a standard left-hand shuttle conveniently placed just beyond the steering wheel for easy access and quick use. This shuttle incorporates a PARK-LOC system that engages the parking brake, as well as forward-neutral-reverse positions.

The engagement aggressiveness can be easily adjusted in CEBIS to provide slow, smooth reaction on slippery surfaces or in tight quarters, or it can be adjusted to provide a faster, more positive shifting behavior for high production work and time-saving shuttle action.

Make multitasking a breeze.

A right-hand reverser is incorporated into the CMOTION handle so shuttling can be comfortably accomplished without taking your hand off the handle while simultaneously controlling other actions like hitch lifting/lowering, F keys controlled functions, and CSM programs.

Simply put the left-hand shuttle into the neutral position, press the orange shuttle button with your thumb, then select the direction of travel by moving the CMOTION handle forward or reverse. Simple, efficient, and comfortable.





Perfect for loaders.

An optional right-hand reverser function is located on top of the ELECTROPILOT joystick control. Here, loader work is easy and comfortable because the direction control and all loader controls are in the palm of your hand.

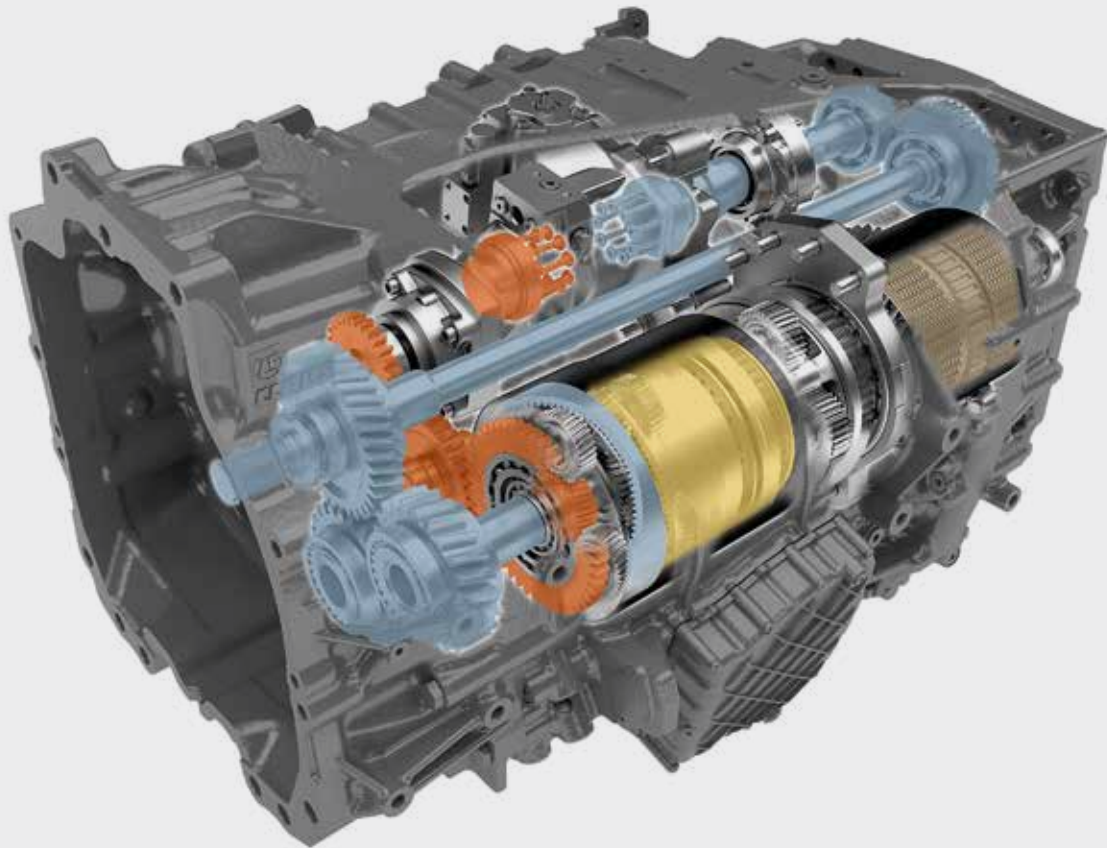
After the left-hand shuttle is placed in the neutral position, simply press the activation button on the front side of the joystick handle and select forward or reverse with the orange buttons on the top of the handle. Ergonomically designed, fatigue reducing options like these are part of why the CLAAS AXION is the premium choice for top producers.

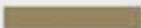
CMATIC. Continuously variable.



-  Reverser
-  Combined hydraulic and mechanical component
-  Split power to the hydrostatic and mechanical drive units
-  Planetary wheel sets for the four mechanical drive ratios



Efficient and user-friendly.

CMATIC is the continuously variable transmission technology used in CLAAS tractors. In the AXION 800 Series, a ZF Terramatic transmission provides efficient conversion of engine power. In this split-power, continuously variable transmission, the mechanical ranges are automatically selected by multi-disc clutches. There is no need to shift between ranges manually.

The high mechanical component in the power transmission provides outstanding efficiency and low fuel consumption in every speed range.

Superior transmission control.

Powerful acceleration, smooth deceleration, and a fast response to changes in load: CMATIC powertrain management shows its maturity in all conditions and for every task. Stay relaxed and focused throughout the work day so you can concentrate on more important things – CMATIC does the rest for you.

Exploiting real potential.

The available power of the transmission can be used effectively at speeds from 0.03 to 31 mph. The high level of mechanical power transmission also delivers outstanding driving force in reverse. What's more, every gear ratio can be used at every engine speed, giving AXION 880 tractors enormous potential for use all year round.

If your foot is not on the accelerator, the transmission is in powered zero mode and maintains its position without creeping or rolling. This means that the tractor can start up safely and easily at steep field entrances or road junctions, even with a full load.

Quiet and comfortable.

Our CMATIC CVT runs quietly in the background to increase operator comfort on those long days in the seat.

AXION model	Transmission version	Engine rpm at maximum speed	Minimum speed (mph)	Maximum speed (mph)
880 and 860	31 mph	1,550	0.03	31
840	31 mph	1,500	0.03	31
820	31 mph	1,600	0.03	31

CMATIC. Optimized settings.



Simple, straightforward operation.

The CMATIC transmission has three operating modes: accelerator pedal, drive lever, and manual mode.

In the first two modes, forward speed can be controlled by the accelerator pedal or drive lever. The engine speed and transmission ratio are adjusted automatically – for optimum efficiency and optimized fuel consumption. In manual mode, the driver chooses the engine speed and transmission ratio. Automatic engine and transmission control is not active.



Accelerator pedal or drive lever.

You can switch between accelerator pedal and drive lever mode while the tractor is moving by pressing a button on the armrest. The active mode is displayed in the CEBIS.

Engine droop at the push of a button.

The engine droop value can be used for quick and easy regulation of the engine speed under full load. The CEBIS terminal clearly displays the engine speed at which the transmission adjusts.

Two engine droop values can be saved for engine droop in accelerator pedal and drive lever mode. They are retrieved by the quick-access facility using the F keys. With these values, known as "Eco" and "Power," the droop can be rapidly adjusted to the task in hand, e.g. when moving from the road to the field. The engine droop for the engine speed memory is defined separately.

Tailor-made speed ranges.

With the CMATIC transmission, three speed ranges can be pre-selected in both directions of travel. The active range is displayed in the CEBIS terminal and can be changed at the touch of a button while the tractor is in motion. The lower the maximum preset value for the range, the more accurately the speed can be controlled.

A cruise control speed can be saved for all the ranges while the tractor is moving by pressing the button on the drive lever. The cruise control speeds can also be pre-set on the CEBIS terminal.



PTO.

All choices in one.



The right speed every time.

The PTO speed is easily pre-selected at the touch of a button. Another button on the armrest activates the PTO.

Automatic PTO engagement/disengagement is activated at a specified linkage height which is continuously adjustable. To save the height, you just move the rear linkage to the required position and give a long press on the automatic PTO button.

The integral freewheel on the rear PTO makes implement hitching simple.

Rotational speeds:

- 1,000 rpm at 1,930 engine rpm
- 1,000 rpm ECO at 1,524 engine rpm
- 540 rpm ECO at 1,595 engine rpm

Standing start.

The 1,000 rpm PTO reaches its full speed precisely in the maximum engine output range. As a result, even heavy PTO-driven implements are no problem for these tractors.

In ECO PTO mode the engine runs at a low, fuel-efficient speed. During light work, the lower engine speed can reduce noise levels and save valuable fuel.

Easy shaft changes.

Switching PTO shafts is easy and mess-free. Simply loosen the cap screws, remove the stub shaft, place the new stub shaft on the locating pins, and reinstall the cap screws by securing tightly. No oil leakage occurs, and there are no snap rings to get lost or corroded.



PTO engagement for front/rear PTO.



Three different size shafts come standard.



External controls for rear PTO on both fenders.

Hydraulics. Powerful, adaptable, efficient.



Pressure-free connections and no mess.

All ten hydraulic couplings at the rear of AXION 880 tractors have release levers, so they can be connected and disconnected even under pressure.

Colored markings on the inlet and outlet sides make it easier to attach implements correctly. Oil leakage lines collect the oil from the couplings when attaching and removing connectors.

Hydraulics that get the job done.

- Load-sensing hydraulic system for all AXION 800 models with 54 gpm output
- Controls for up to seven electronic spool valves on the armrest – four of which can be operated by ELECTROPILOT. Thanks to free assignment and prioritization of the spool valves, every driver can adapt CEBIS operation according to the task in hand and personal preference. The frequently-used hydraulic functions are positioned side by side for smooth operation.
- Spool valve operation can be assigned to the F keys on the CMOTION, multifunction armrest, or ELECTROPILOT to lighten the workload during combined operating processes

Front and rear linkage.
Lift any implement.



Direct adjustment.

The main rear linkage functions are directly accessed via push buttons and dials on the right-hand B-pillar:

- Manual lift and lower for machine attachment
- Vibration damping on/off
- Lock rear linkage
- Activate slip control
- Lifting height limiter
- Lowering speed
- Draft and position control
- Adjustment of wheel slip control

The rear linkage.

With a maximum lifting capacity of over 21,000 lbs, these tractors can carry the heaviest of implements.

- Wheel slip control via radar speed
- Hydraulic top link
- Excellent view of linkage and drawbar
- Both fenders are fitted with external controls for the rear linkage, PTO, and one of the spool valves



Front linkage and front PTO.

All models feature an optional front linkage and front PTO:

- Three positions for the front lower links: folded up, fixed working position, and float position in slotted hole
- Double-acting lift rams as standard
- Short distance between front axle and mounting points for improved guidance of front attachments
- 1,000 rpm PTO
- External control of the front linkage and one double-acting spool valve
- Maximum lift capacity of over 10,000 lbs

Precise work.

The optional front linkage position control system for CEBIS enables front-mounted implements to work extremely accurately. The working position is adjusted via a rotary knob on the armrest, while the lifting height can be limited and the lifting and lowering speed can be set using CEBIS. The front linkage can be used in single- or double-acting mode.

Always connected.

Optional hydraulic and electronic interfaces for many applications are incorporated into the front linkage:

- Up to two double-acting spool valves
- Free-flow return line
- 7-pin socket
- ISOBUS socket



Position and load control are easy to set and adjust.



When a front linkage is installed, two hydraulic valves and one free-flow return line are available the front. Ideal for front-mounted equipment.

The cab.
A clear view.



The right equipment for all operations.

Spacious and quiet, with large windows and full suspension: the cab on the AXION tractor guarantees maximum comfort throughout long working days. CEBIS with touch display operation and the innovative CMOTION multifunction control lever.

4-pillar concept.

The CLAAS 4-pillar cab offers some distinct advantages:

- Clear view of the full working width of attached implements
- Large-volume cab creates an extremely spacious working environment
- Continuous windscreen



The cleverly positioned rear cab pillars and convex rear window give the driver an excellent view of the implement and hitch area.



CEBIS. Simply everything.

CEBIS features electronic spool valves and the superb CEBIS terminal with a 12" touch display. As well as enhanced automatic functions such as CSM headland management and spool valve prioritization, it also offers many other functions – CEBIS leaves no stone unturned. All settings can be entered in seconds thanks to touchscreen operation and logical menu navigation.

AXION equipment	CEBIS
CEBIS touchscreen terminal, CMOTION multifunction control lever and multifunction armrest	●
CMATIC continuously variable transmission	●
PTO shaft management	●
Max. number of electronic spool valves	7
Max. number of electronic spool valves operated by ELECTROPILOT	4
CSM headland management with edit function	●
Implement management	●
Tractor task management	●
Camera image	●
ISOBUS implement control	●
CEMOS for tractors	□
TELEMATICS and other online functions	□

● standard ○ optional □ available – not available

CEBIS. Simply everything.



An armrest that sets new standards.

All the main controls are integrated into the right-hand armrest:

- 1 CMOTION multifunction control lever
- 2 Control panel for drive mode, range changing, and two engine speed memories with fine adjustment
- 3 CEBIS terminal with 12" touch display
- 4 ELECTROPILOT with two double-acting spool valves and two F keys
- 5 CEBIS control panel
- 6 Working depth adjustment for front and rear linkage
- 7 Front and rear PTO activation
- 8 Hand throttle
- 9 Transmission in neutral
- 10 Electronic spool valves

- 11 Four-wheel drive, differential lock, automatic PTO engagement/disengagement, front axle suspension
- 12 Main switch: battery, electronic spool valves, CSM, steering system

The height and position of the armrest can easily be adjusted to the driver's requirements.

Functions that are used less frequently, such as PTO speed preselection and the main switches, are located to the right of the driver's seat. When the driver's seat is rotated, the electronic linkage control system can be operated comfortably with an excellent view of the attached implement. Fine adjustment of the settings can then take place while work is in progress. Two additional buttons enable you to raise and lower the rear linkage manually for easier implement attachment.



At the push of a button.

The free assignment option for the ten function buttons on the CMOTION means that there is no longer any need to reposition your hands while you work. All implement-specific ISOBUS functions are easily controlled using the CMOTION:

- ISOBUS functions
- Event counter on/off
- Spool valves

Rear linkage functions on the CMOTION:

- Lower to preset working position
- Raise to the preset lift height position
- Manual activation: lift and lower at two speeds (slow/fast)
- Quick implement entry

CMOTION multifunction control lever.

The CMOTION is a CLAAS concept which makes using the main functions of the AXION tractor easier and more efficient. Functions are controlled using your thumb and forefingers, allowing your hand to stay in one place for the majority of time and preventing fatigue.



Clear layout and fast operation.

The 12" CEBIS screen uses self-explanatory symbols and color coding to give a clear picture of the settings and operating statuses. Thanks to the CEBIS menu structure and touch-sensitive screen, all settings can be entered in just a few steps.

A particularly attractive feature is the DIRECT ACCESS function with the machine silhouette. One touch is all it takes to go straight to the right menu window.

As well as screen-based operation with the CEBIS, there is a set of buttons in the armrest. Full CEBIS operation is available using the rotary/push switch and ESC button if uneven ground reduces the accuracy of fingertip operation. The DIRECT ACCESS button takes you straight to the settings for the last used tractor function.

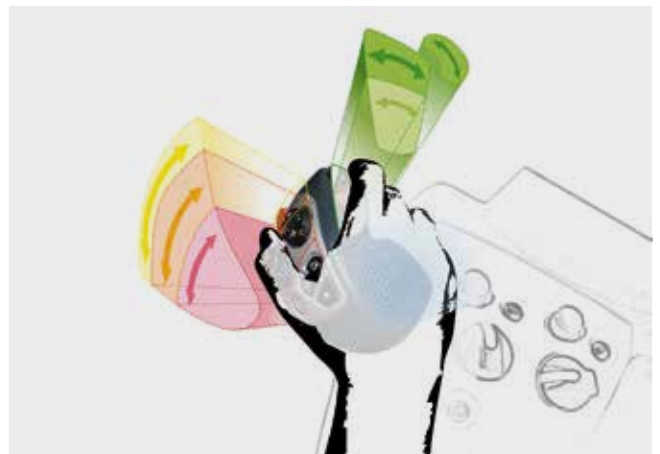

Ergonomics and comfort for optimum working conditions.



First-class comfort.

The AXION has several practical features which make it the ideal choice for long working days. A large number of storage options means that the driver can always find space for a mobile phone or documents. Under the passenger seat there is a cooler compartment which has room for two 1.5 liter bottles and snacks. Perfect for your lunch break.

LED headlights for perfect illumination.

If you're still working when it goes dark, the work lights will light up the whole of the area around the machine, so you can see exactly what you're doing. For even more demanding situations, up to 20 LED work lights and four LED road lights can illuminate the entire surroundings of the AXION almost as brightly as daylight.

A pleasant place to work.

All AXION models are fitted as standard with air conditioning and, optionally, with a category 3 filter. All components are built into the double-insulated cab floor to ensure quiet operation.



As well as the manually controlled air-conditioning system, a fully automated setting is available which provides a pleasant flow of air through the cab



Clear and logical layout.

The instrument panel is mounted on a fully adjustable steering column. It pivots with the column to give an unimpeded view of the controls at all times.



Illuminated interior.

When the road lights are switched on, all the controls and the symbols on all the switches are illuminated. You have the option to select a darker color scheme in CEBIS.



Leather on request.

The driver and passenger seat are available with modern, non-slip fabric or elegant, easy-care leather upholstery.



Sockets in easy reach.

All the sockets for the power supply as well as ISOBUS sockets for additional terminals are located under the right console.



Bluetooth mobile phone connection.

With the built-in Bluetooth hands-free device with external microphone, you can make clear calls from the comfort of your cab.



More fresh air.

Front opening roof avail as option (see configurator for picture)



Wide-angle for better visibility.

As well as the large standard mirror, a wide-angle mirror for improved road safety is supplied as standard.



Non-slip leather steering wheel.

The robust leather steering wheel provides a secure grip and an uninterrupted view of the instrument panel whatever position it's in.



Tinted rear window.

The tinted rear window (optional) helps maintain a comfortable cab environment and reduces glare when you're working in the low evening sun.

Suspension.

Protects both driver and machine.



Full 4-way suspension.

Four suspension points mean that the cab is fully isolated from the chassis, preventing impacts and vibration from reaching the driver. Longitudinal and lateral struts join the suspension points and keep the cab stable when turning corners or braking. The entire suspension system is completely maintenance-free.



Premium comfort.

The standard seat is cloth-covered, air-suspended, and pivoting for every-day comfort. With options to include heat and semi-active air suspension, all day operation is no problem. For the absolute premium in comfort and luxury, choose the leather-wrapped seat for easy care and long wear life.



PROACTIV front axle suspension – complete comfort automatically.

The suspension adjusts to tractor loading and automatically remains in the central position. Changes in load due to braking and turning maneuvers are also compensated. Parallelogram axle suspension and 3.5 inches of spring travel guarantee a smooth ride.



Vibration damping.

Heavy implements mounted on the front and rear create a load on the tractor as well as the driver. The front and rear linkage are both equipped with vibration damping to compensate for peak loads during transport operations and when the attached implement is raised at the headland.

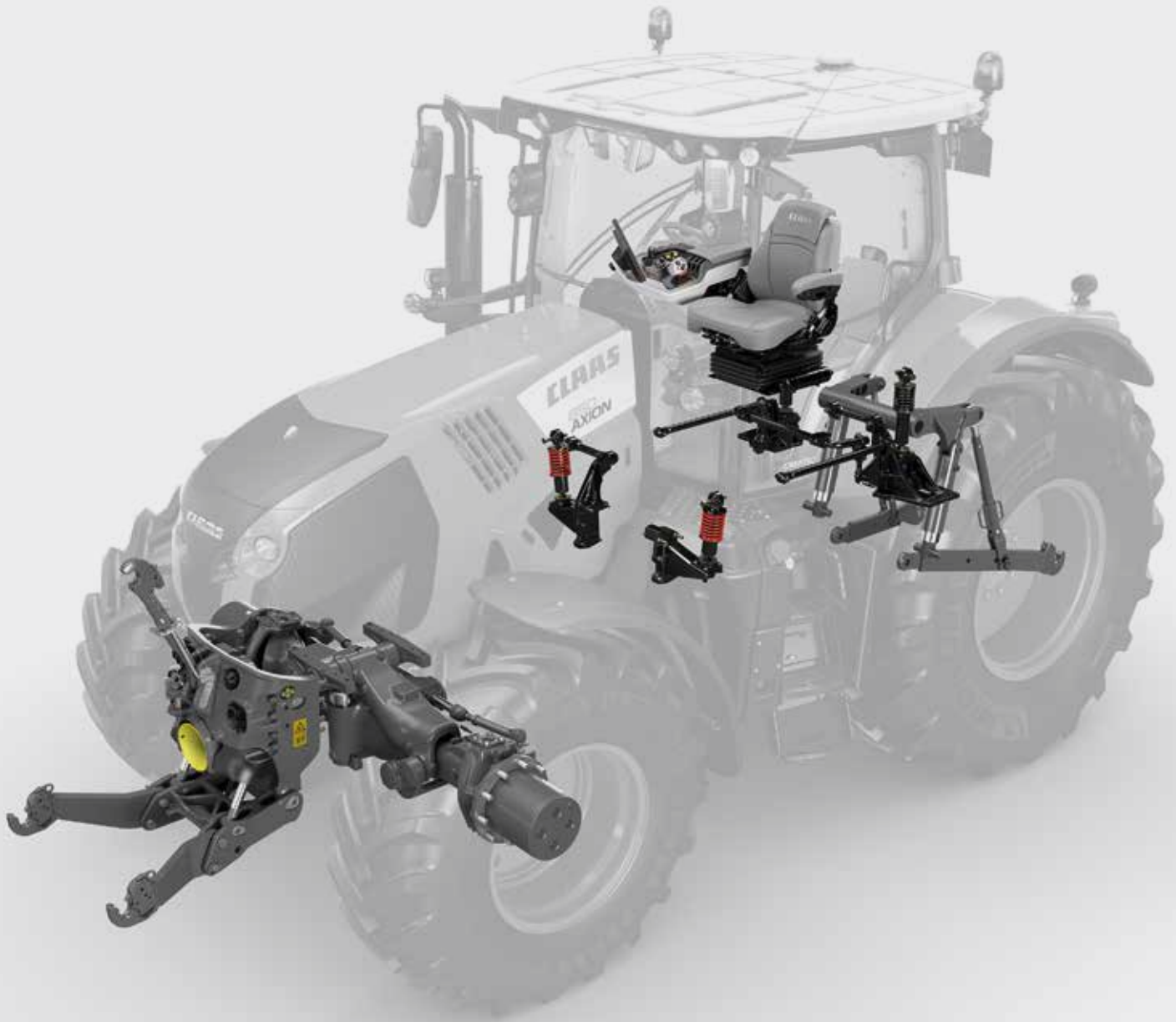

Switch to activate front axle suspension.

Get more done.

Operator assistance systems.

There is no substitute for your experience. It's what allows you to respond quickly and appropriately to the challenges you face in your daily work. When you're dealing with difficult terrain or changing soil conditions, you have to make decisions very quickly to get the job done to the right standard. That's why it's good to be able to count on a tractor with CEMOS to reduce your workload.

Data management.

Data has long since become an indispensable resource. To profit from its full potential, you should take just as good care of your data as you do your machinery fleet. And that includes making sure all systems, machines and processes are meaningfully connected and the data generated is sent to the appropriate place for analysis.



CEMOS drivers are unbeatable.

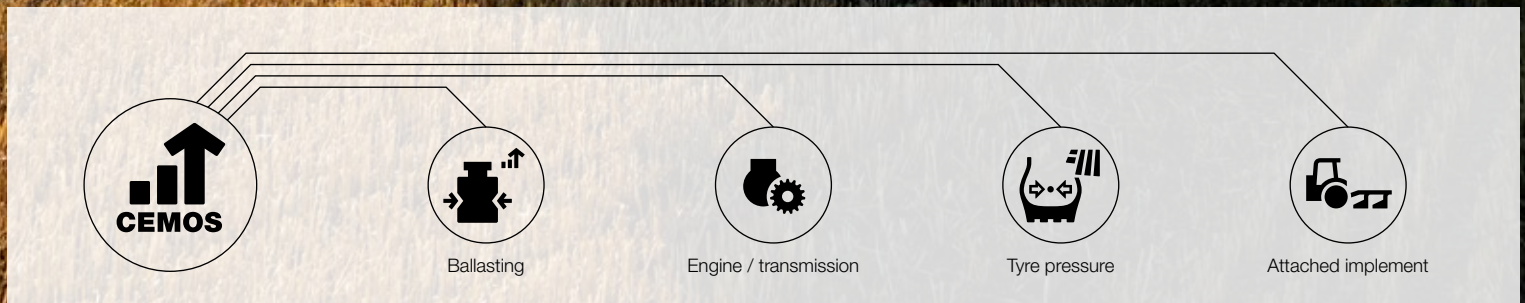

CEMOS teaches itself and trains the user.

The CEMOS self-learning operator assistance system is the only one of its kind on the market to optimize the performance of both the tractor and attached implements such as ploughs and cultivators. So it helps the driver set the correct ballast and tire pressure. CEMOS uses a dialogue-based interface to make recommendations for all important settings, e.g. for the engine, transmission and implement. This helps to ensure optimum traction and soil protection at all times. With CEMOS you can increase your work rate, improve the quality of your work and reduce your fuel consumption by 16.8%.

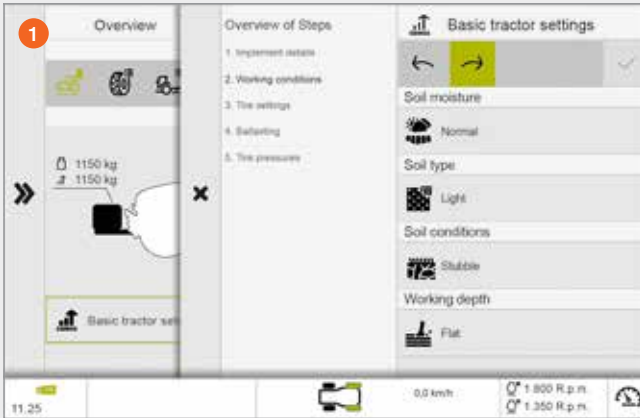

Phase 1.
Preparation in the farmyard.

CEMOS recommends the required ballasting and optimum tire pressure to suit the selected implement and task before the driver has left the farmyard. The dynamic learning system gathers more measurements while work is under way, and adapts its recommendations accordingly next time around.



Phase 2.
Basic setting in the field.

The integrated CEMOS knowledge database provides step-by-step instructions on basic settings for implements, with illustrations. These provide valuable assistance for drivers working with new or unfamiliar implements.

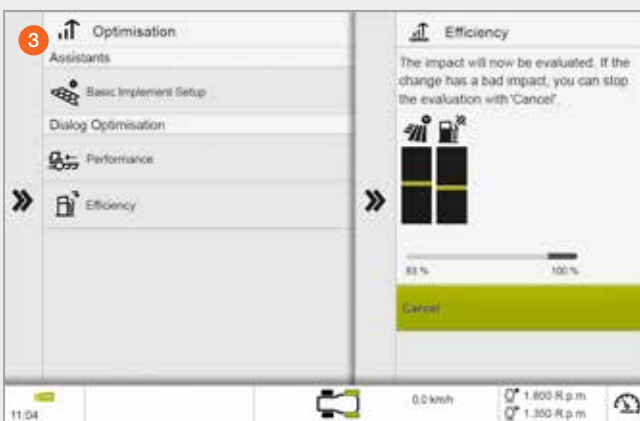

Phase 3.
Optimization while work is under way.

The driver opens the optimization dialogue in the field. CEMOS checks all the basic settings, and offers suggestions for improving "performance" and "efficiency", which the driver can accept or reject. After each change of setting, CEMOS recalculates and shows whether the work rate and fuel consumption have improved, and by how much.

Precision at the headland with CSM.



CLAAS SEQUENCE MANAGEMENT.

CSM headland management takes the load off you whenever you need to manoeuvre at the headland. You can run any of the previously recorded functions simply by pressing a button.

	With CEBIS
Number of storable sequences	Four per implement, up to 20 implements
Sequence activation	CMOTION and F keys
Sequence display	On CEBIS display
Recording mode	Time- or distance-related
Edit function	Subsequent sequence optimization in CEBIS

The following functions can be combined in any order:

- Spool valves with time and flow control
- Four-wheel drive, differential lock and front axle suspension
- Front and rear linkage
- Cruise control
- Front and rear PTO
- Engine speed memory





Easy to record and run.

Sequences can be recorded on a distance- or time-related basis. In recording mode, clear symbols guide the driver step-by-step through the process of creating the sequence on the CEBIS color display. A sequence that is running can be paused and restarted simply by pressing a button.



Non-stop optimization with CEBIS.

Recorded sequences can be changed and optimized in CEBIS at a later date. Steps can be added and deleted or changed and adapted in minute detail, allowing times, distances and flow volumes to be tailored to current conditions. Once a sequence has been recorded, it can be refined down to the last detail in just a few steps.

GPS PILOT CEMIS 1200.

Precision farming made easy.

Precise, future-proof, simple.

Improve the profitability of your farm and simplify day-to-day operations – step into the future with the CEMIS 1200 terminal.

With the GPS PILOT automatic steering system, your harvesting machine will seem like it's running on rails: always on the right track, using the full working width with no overlapping. There's no need for a long induction course. You'll be surprised how easy it is to operate an automatic steering system using the intuitive CLAAS user interface.

Thanks to ISOBUS and standard data exchange formats, the CEMIS 1200 is the way forward for more precision in farming.

CEMIS 1200 terminal.

The CEMIS 1200 fits seamlessly into the cab: with the same intuitive control logic as CEBIS, operators will quickly find their way around.

You can use the system on all CLAAS machines set up for GPS PILOT CEMIS 1200. The terminal and receiver can be transferred from one machine to another in next to no time, giving you complete flexibility and saving money into the bargain.

Benefits:

- Intuitive user interface for outstanding ease of use day and night
- Quick access to all important functions
- Freely configurable working areas for custom control





Precision guidance.

You need a good correction signal for precise work. It's a given with SATCOR 15¹ as standard for 5 years.

Need even greater accuracy?

Choose the optional SATCOR 3¹ and SATCOR 3 FAST¹ correction signals (\pm inches).

Absolute precision your top priority?

Choose the GPS PILOT CEMIS 1200 with RTK correction signal for the highest possible repeatable accuracy (\pm inches).

RTK Bridging.

All RTK correction signals are enhanced by the RTK Bridging function as standard, so if the signal is lost, work can continue for up to 20 minutes with gradually decreasing accuracy.

Difficult topography or mobile phone dead zones in your area?

With RTK Bridging Premium you can carry on working – without loss of accuracy or time limits.

¹ SATCOR 15 / SATCOR 3 / SATCOR 3 FAST powered by Trimble RTX. SATCOR correction signals, RTK Bridging and RTK Bridging Premium are not available in all regions. Together with your CLAAS distributor, we will find the best solution for your individual requirements.

GPS PILOT CEMIS 1200. Moving with the times.

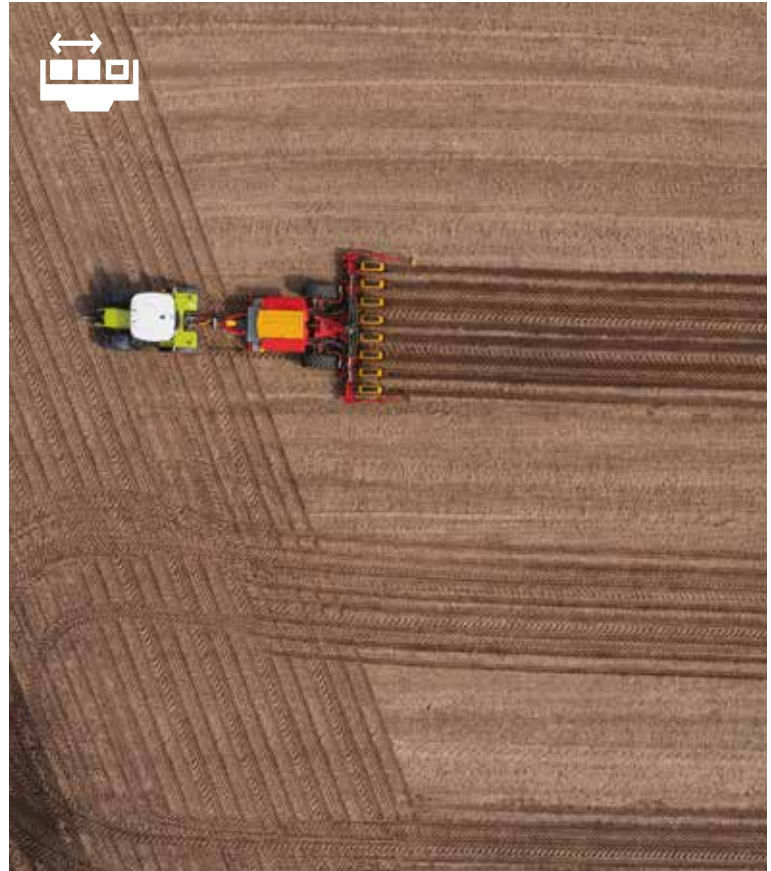

Future-proof – GPS PILOT CEMIS 1200.

With GPS PILOT CEMIS 1200, you get a terminal fit for the future. Tailor-made for your farm, with full functionality pre-installed or added gradually to suit your growing needs.

Still not sure? Why not test additional functions and correction signals free of charge in advance?

Perhaps your requirements have changed during the season? No problem – with the digital connection you can adapt the system's functions quickly and flexibly to suit your needs. The appropriate license or activation can be transferred online straight to your terminal.¹



ISOBUS Universal Terminal (ISO UT).

The ISO UT implement view can be displayed in the main work screen or in the smaller implement screen. This enables you to customize the display settings to suit your needs. The AUX-N allows functions to be assigned to physical function keys, for example on the CLAAS multifunction control lever.

Benefits:

- Customizable display settings for ISOBUS implements in the CEMIS 1200 terminal
- User-friendly operation using function keys
- Transfer new licenses online or activate directly on the terminal

¹ in countries with CLAAS connect



ISOBUS TC Section Control.

The ISOBUS functionality of the CEMIS 1200 allows you to switch sections on or off automatically – for all the precision and none of the hassle.



Precision farming and documentation with ISOBUS TC-GEO and VRA.

With ISOBUS TC-GEO you can easily record geo-referenced data such as application rates. If you want to target applications to specific areas, simply add the VRA (Variable Rate Application) module.



Office and machine seamlessly connected. Task management.

With the CEMIS 1200 you can handle your job management via your mobile phone connection in just a few clicks – it's standardized and convenient.

Plan your tasks in your farm management software and transfer them straight from 365FarmNet or other connected systems to the machine via TELEMATICS. The operator has all the tasks in sight and can quickly and easily send them back to the office on completion.

Assign, complete and document – seamlessly and reliably.

A connected tractor is more productive.

Digitalization pays.

Digitalization is a key factor in increasing your productivity and efficiency. Data generated in completely different places can be collected and evaluated centrally. This conserves your resources and improves your business processes.

To enable you to get more out of the AXION and your other machines, CLAAS offers a range of modules which allow systems, technology and working processes to be connected with each other, regardless of the manufacturer. Intelligent digitalization matched to the requirements of your farm can reduce your workload significantly.

- Transfer and document machine and job data quickly
- Manage individual machines and the whole fleet efficiently
- Analyze working processes carefully and optimize them
- Analyze fields easily and map yields precisely
- Call up and manage farm data with intelligent farm management software
- Transmit data from different manufacturers' machines to TELEMATICS smoothly
- Save valuable maintenance and service time with remote diagnostics



TELEMATICS records your success.

With TELEMATICS you can continuously retrieve and record work and performance data for your tractor. All data are transmitted via the mobile phone network from the machine to the server, where they are processed and stored. You can access and evaluate your data online in real time or retrospectively via the web portal or the TELEMATICS app. The Connected Documentation license amalgamates all the data on a field-specific basis in the background. It is also possible to export your data to any current farm management software program.

CLAAS API connects your office to your fleet.

With the DataConnect function, CLAAS, 365FarmNet, John Deere, Case, Steyr and New Holland have created a direct, multi-manufacturer, industry-wide and open cloud-to-cloud solution. This allows you to control and monitor your entire machinery fleet in the CLAAS TELEMATICS portal – safe in the knowledge that all relevant data are exchanged securely, conveniently and fully automatically. Both systems are components of CLAAS TELEMATICS.

Remote Service costs you nothing.

Remote Service from CLAAS is an important machine networking element. It simplifies maintenance and service support significantly. The machine informs the service partner of an upcoming requirement for maintenance or sends immediate notification if a fault arises. The service partner has access to the relevant data and can prepare optimally for the intervention in both scenarios. CLAAS covers the cost of Remote Service for you during the first five years. All you have to do is give your consent.

NEW: CEMIS 1200 manages your jobs.

With CEMIS 1200 and an active Connected Documentation license, you can do your task management online with just a few clicks. Plan your tasks in your farm management software and transfer them to the machine via TELEMATICS. The operator has all the tasks in sight and can quickly and easily send them back to the office on completion.

**Digitalization puts your farm ahead.**

- TELEMATICS transfers your data from your machine straight to the cloud
- DataConnect allows you to process data from your machines, regardless of manufacturer
- With CEMIS 1200 you can create and manage all jobs on the spot in the machine.
- Remote Service simplifies maintenance and service support

Maintenance.
Fast and straightforward.



The front axle lubrication points are located in front of the radiator assembly for optimum accessibility.



The battery is conveniently positioned above the right-hand access ladder.



Integrated maintenance counter.



A lubrication chart under the hood simplifies maintenance.



Good access saves time and money.

Daily maintenance work should be as straightforward as possible – because we know from experience that nobody enjoys doing things that are complicated or inconvenient.

- The hood opens at the press of a button, providing access to all the engine maintenance points
- The engine oil can be checked and topped off on the left-hand side of the tractor when the hood is closed
- All daily maintenance tasks can be carried out without tools
- The front axle lubrication points are located in front of the radiator assembly for optimum accessibility
- The fuel prefilter is conveniently located by the left-hand cab access ladder
- Large drawer in the left-hand access ladder with space for a standard toolbox

The long oil-change intervals (engine 600 h, transmission and hydraulics 1,200 h) save time and money. As a result, less valuable working time is lost during the season and the tractor is where it should be – at work.



Fresh air for full power.

The large intake panels in the hood provide plenty of fresh air for cooling and for the engine air filter. Low flow rates at the intake panels help them to stay clean and permeable at all times.

The radiator assemblies are supported by a robust frame and gas-filled shock absorbers open the radiator panels to two positions for thorough cleaning. Cleaning can therefore be carried out safely and conveniently as required.

The air filter is accessibly located in the cool zone in front of the radiator panels so it can be removed without hindrance. Coarse dirt particles are extracted in the filter housing, further extending the cleaning interval.

Whatever it takes.
CLAAS Service & Parts.



Specially matched to your machine.

Precision-manufactured parts, high-quality consumables and useful accessories. Choose our comprehensive product range to be certain of receiving exactly the right solution to ensure 100% operating reliability for your machine.



For your business: CLAAS FARM PARTS.

CLAAS FARM PARTS offers one of the most comprehensive ranges of multi-brand parts and accessories for all agricultural applications on your farm.



Safeguard your machine's reliability.

Increase your operating reliability, minimize the risk of breakdown and repair. MAXI CARE offers you predictable costs. Create your own individual service package to meet your particular requirements.

Remote Service.

With Remote Service, all the relevant data from your telematics-equipped machines are made available to your service partner. This greatly simplifies the remote diagnostic process and the provision of remote support. Servicing can be carried out more efficiently and the level of machine readiness for use is enhanced. Remote Service is provided to you free of charge for a period of five years. All you have to do is give your consent.



Global supply.

The CLAAS Parts Logistics Center in Hamm, Germany, stocks almost 200,000 different parts and has a warehouse area of over 183,000 square ft. This central spare parts warehouse delivers all ORIGINAL parts quickly and reliably all over the world.



Your local CLAAS distributor.

Wherever you are, you can count on us to always provide you with the service and the contact people you need. Your CLAAS partners are on hand in your local area, ready to support you and your machine around the clock. With know-how, experience, commitment and the best technical equipment. Whatever it takes.





These outstanding features speak for themselves.



CLAAS POWER SYSTEMS.

- FPT engines for high performance and low fuel consumption
- CMATIC continuously variable transmission available with CEBIS standard
- Long wheelbase and balanced weight distribution
- Rear tires up to 900 mm wide and 2.05 m in diameter
- Choice of 540, 1000, 540 ECO or 1000 ECO PTO mode
- Up to seven spool valves and 54 gpm hydraulic capacity

Comfort and convenience.

- 4-pillar cab
- CMOTION multifunction control lever
- 4-point cab suspension
- Driver's seats with active suspension and ventilation
- PROACTIV front axle suspension
- Front and rear linkage with vibration damping
- Optimum accessibility and labelling for all maintenance points
- Drawer with toolbox built into the tractor
- GPS PILOT automatic steering and online task management via the CEMIS 1200 terminal
- CSM headland management
- CEMOS for tractors
- Implement management
- TELEMATICS
- ISOBUS implement control via the CEBIS or CEMIS 1200 terminal

Specifications.

AXION		880	860	840	820
Dimensions and weights					
Standard					
Overall height (a)	in	126.50	126.50	126.50	126.50
Length: front linkage folded (b)	in	213.70	213.70	213.70	213.70
Wheelbase (c)	in	117.32	117.32	117.32	117.32
Ground clearance, front axle (d)	in	18.50	18.50	18.50	18.50
Ground clearance, rear axle (e)	in	20.71	20.71	20.71	20.71
Weight	lbs	19952/20834	19180/20834	18519/20172	18298/19952



AXION		880	860	840	820
Engine					
Manufacturer		FPT	FPT	FPT	FPT
Number of cylinders		6	6	6	6
Cubic capacity	L	6.7	6.7	6.7	6.7
Variable geometry turbo		●	●	●	●
Engine fan		VISCTRONIC	VISCTRONIC	VISCTRONIC	VISCTRONIC
Rated output (ECE R 120) ¹	kW/hp	199/270	184/250	165/225	151/205
Max. output (ECE R 120) ¹	kW/hp	206/280	194/264	173/235	158/215
Max. output with CPM (ECE R 120) ¹	kW/hp	217/295	–	–	–
Rated output type approval value for CMATIC models ²	kW/hp	209/280	192/257	179/240	168/225
Max. output type approval value for CMATIC models ²	kW/hp	221/296	204/273	188/252	175/235
Max. torque	lb ft	941	835	749	694
Max. fuel tank capacity	gal	120	120	120	120
Oil-change interval	h	600	600	600	600
CMATIC continuously variable transmission					
REVERSHIFT clutchless reverser		●	●	●	●
Min. speed at rated engine speed	mph (km/h)	.031 (0.05)	.031 (0.05)	.031 (0.05)	.031 (0.05)
Max. speed	mph (km/h)	31 (50)	31 (50)	31 (50)	31 (50)
Rear axle					
Max. diameter of rear tyres	in	6.725	6.725	6.725	6.725
Widest rear tyres		900/60 R 38	900/60 R 38	900/60 R 38	900/60 R 38
Flanged axle		●	●	●	●
Quick-release axle 3.0 m wide		●	●	●	●
Automatic differential locks		●	●	●	●
Park lock		●	●	●	●
Oil-change interval	h	1200	1200	1200	1200
PTO					
External operation of engagement and emergency stop		●	●	●	●
540 ECO / 1000 / 1000 ECO		●	●	●	●
PTO shaft stub: 1½" with 6 or 21 splines and 1¾" with 20 splines		□	□	□	□
Four-wheel drive front axle					
PROACTIV suspended front axle		●	●	●	●
Automatic 4-wheel drive		●	●	●	●
Turning radius	ft	17.42	17.42	17.42	17.42

¹ Meets ISO TR 14396

² Performance data fit criteria for admissibility.

● standard ○ optional □ available – not available

AXION		880	860	840	820
Hydraulics					
Load-sensing hydraulics 54 gpm		●	●	●	●
Max. operating pressure	psi	2900	2900	2900	2900
Number of electronic spool valves		5-7	5-7	5-7	5-7
Two central electronic spool valves, operated from ELECTROPILOT		○	○	○	○
Flow rate control		●	●	●	●
Rear linkage					
Max. lift capacity at ball ends	lbs	22487	22487	21385	21385
Continuous lift capacity at 24 in	lbs	13669	13669	13669	13669
Vibration damping		●	●	●	●
External controls		●	●	●	●
Active wheel slip control		○	○	○	○
Front linkage					
Lift capacity	lbs	10361 / 13007	10361 / 13007	10361 / 13007	10361 / 13007
Front PTO 1000 rpm		○	○	○	○
Vibration damping		●	●	●	●
Position control		○	○	○	○
External front linkage operation		○	○	○	○
Four additional hydraulic connections		○	○	○	○
External operation of additional connections		○	○	○	○
ISOBUS and trailer socket		○	○	○	○
Cab					
CEBIS		●	●	●	●
4-point suspension		●	●	●	●
Multifunction armrest		●	●	●	●
Automatic climate control		●	●	●	●
Passenger seat with integral cool box		●	●	●	●
Data management and operator assistance systems					
CEMOS		●	●	●	●
CSM headland management		●	●	●	●
ISOBUS		●	●	●	●
GPS PILOT ready		●	●	●	●
GPS PILOT steering system		○	○	○	○
TELEMATICS		●	●	●	●
Remote Service		●	●	●	●

CLAAS continually develops its products to meet customer requirements. This means that all products are subject to change without notice. All descriptions and specifications in this brochure should be considered approximate and may include optional equipment that is not part of the standard specifications. This brochure is designed for worldwide use. Please refer to your nearest CLAAS dealer and their price list for local specification details. Some protective panels may have been removed for photographic purposes in order to present the function clearly. To avoid any risk of danger, never remove these protective panels yourself. In this respect, please refer to the relevant instructions in the operator's manual.

All technical specifications relating to engines are based on the European emission regulation standards: Stage. Any reference to the Tier standards in this document is intended solely for information purposes and ease of understanding. It does not imply approval for regions in which emissions are regulated by Tier.

● standard ○ optional □ available – not available



CLAAS of America Inc.
8401 S 132nd Street
Omaha, NE 68138
Phone (402) 861-1000
www.claas.com

CL99881070 / 06/2024